

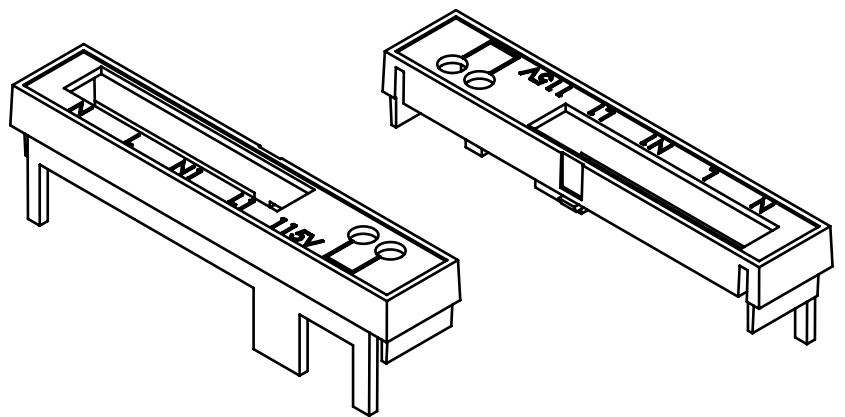



SECTION A-A

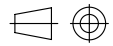

General information:

-  Workpiece zero point for mechanical processing
- Minimum recommended radius for machining = R1.0 mm

General Tolerance UNI EN 22768/1 Media (m)					Sheet:	
from 0.5 to 3 ± 0.1	from 3 to 6 ± 0.1	from 6 to 30 ± 0.2	from 30 to 120 ± 0.3	from 120 to 400 ± 0.5	1	
Scale: 1:1	Drawed:	Checked: R.N.	Date: 29/06/2023	Material: PC/ABS	Process: INJECTION	
 Dimension in mm	Derived from: --			Weight: 3.35 gr	Cod. Mold: ST.05CN002	
 italtronic enclosures for electronics italtronic.com				Description: COPRIMORSETTO SPECIALE 4M-CM056 2 VIE 4MP05 TERMINAL COVER MODULBOX 4M-CM056 2POLES		
Drawing nr.: 2_250_00160				Rev.: 00		A4