

SECTION A-A

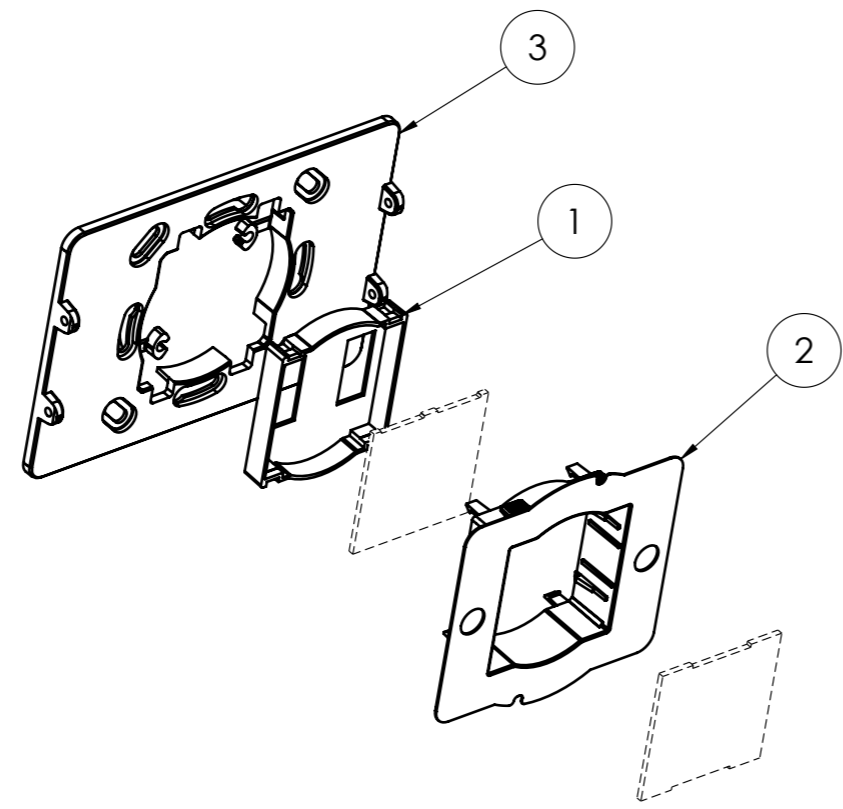

General information:  
 - Workpiece zero point for mechanical processing  
 - Minimum recommended radius for machining = R1.0 mm

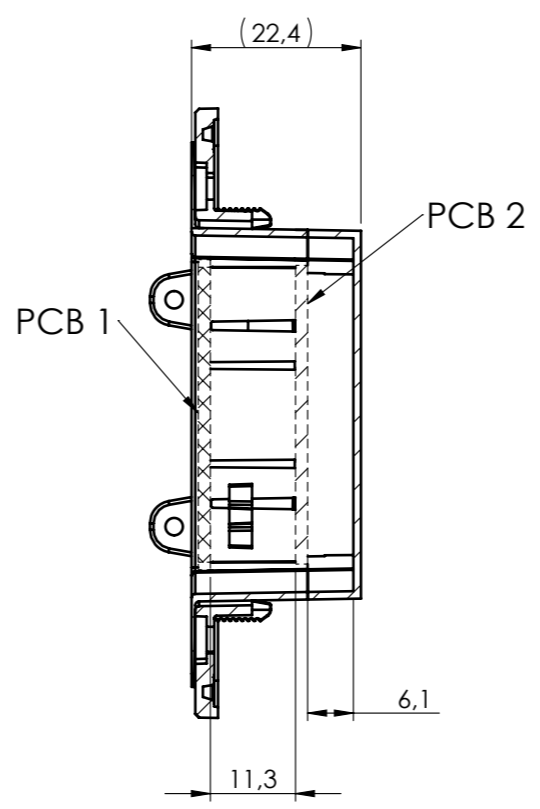
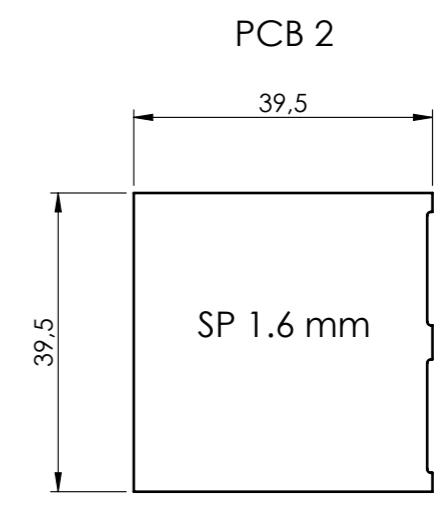
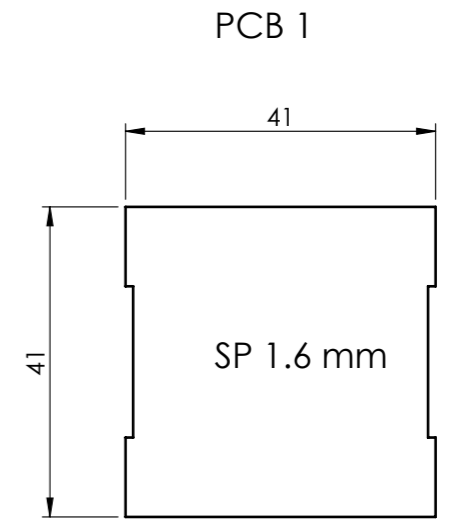

RIF.	Q.TY	DRAWING	DESCRIPTION
1	1	2_020_00004	REAR CLOSURE WITH HOOKS D60 H20
2	1	2_020_00002	BODY ENCLOSURE D60 H20
3	1	2_010_00003	ITOUCH 80X120 REAR FRAME FOR D60 BOX

General Tolerance UNI EN 22768/1 Media (m)					Sheet:
from 0.5 to 3 ± 0.1	from 3 to 6 ± 0.1	from 6 to 30 ± 0.2	from 30 to 120 ± 0.3	from 120 to 400 ± 0.5	1
Scale: 1:1	Drawed: R.N.	Checked: R.N.	Date: 01/03/2023	Material:	Process:
Dimension in mm	The present drawing cannot be reproduced or communicated to 3rd parties, even partially, without the authorization of ITALTRONIC S.p.A. Italtronic reserves to protect its own rights according to the law.			Weight: gr	Cod. Mold: --

**italtronic**  
enclosures for electronics  
italtronic.com

Derived from: --

Description:  
KIT PLACCA POSTERIORE PER SCATOLA D60 H20  
REAR PLATE KIT FOR D60 H20 BOX

Drawing nr.: **3\_010\_00003**

Rev.: 00 A3